

LPG modules

according to PED/2014/68/UE

The tanks we produce are CE marked, which allows them to be freely used in the European Union. Underground tanks are equipped with an access manhole with a cover with fittings.

They are made of carbon steel and fulfill the safety requirements of propane and butane storage. We hold current permits to manufacture such tanks issued by a Notified Body.

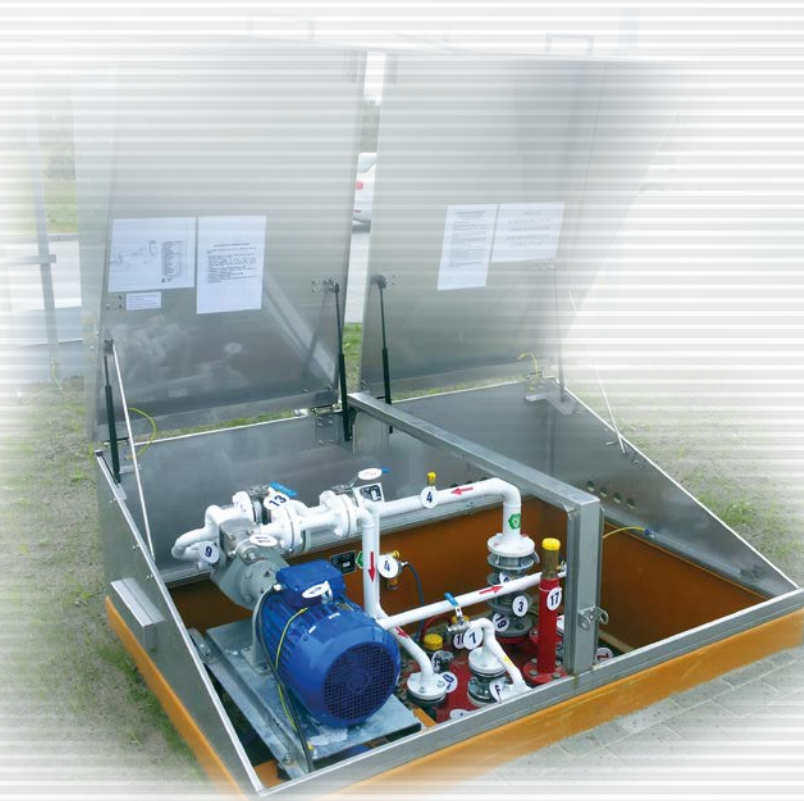

CE Certificate



Volume	Diameter	TOTAL Length*	TOTAL Height	TOTAL Weight
[m ³]	[ø]	[mm]	[mm]	[kg]
9	1 250	7 830	1 920	1 666
9,9	1 600	5 510	2 270	2 231
15		8 010	2 270	3 015
9,9	2 000	3 720	2 670	2 214
14,5		5 220	2 670	2 903
20,5		7 220	2 670	3 820

* Total length in tolerance to +0,5% according to norm



Standard equipment of LPG module

- LPG tank with a manhole
- LPG pump Corken FD/DLD 150 and fittings
- in the tank-pump system:
 - pump type: DLD 150
 - electric motor power: 5,5 kW

Fittings

- ball valve DN 25
- filter DN 50

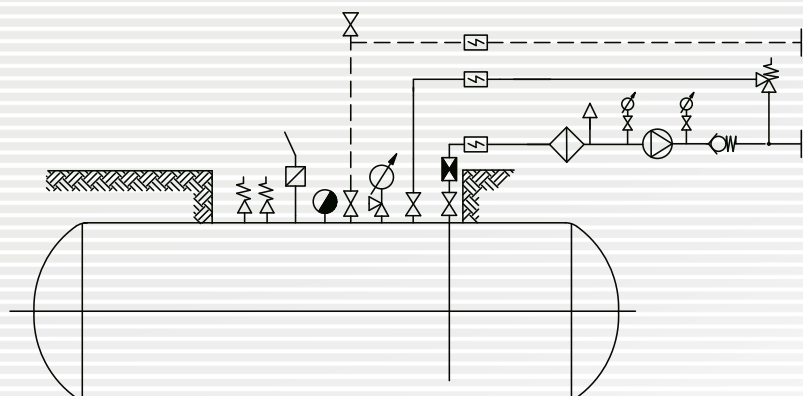
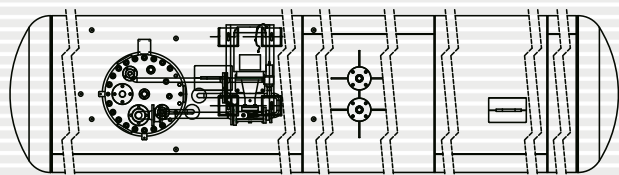
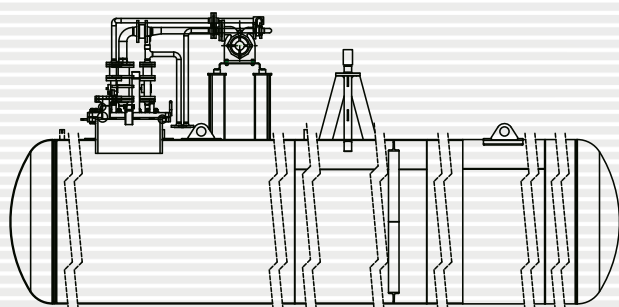

- check valve DN 25
- pump manometer 63 mm with the valve
- excess flow valve m/k DN 50
- composite bypass valve
- hydrostatic valve
- pump absorber

Installation and commissioning

- piping installation on pump input DN 40/50 (with CE)
- installation of bypass Valve line – return of the liquid phase
- assembly of the pumping unit on a support tank construction
- tightness test*
- commissioning of the installation
- training in the basic operation
- installation marking according to technical diagram

***NOTE:** the above range of action does not include LPG dispenser and piping installation from pump to the dispenser each will be a subject to individual valuation

Documentation

- documentation for the closed circuit pipe above DN 25
- leak test protocol
- conformity declaration of pipeline
- certificates for equipment and fixtures

Offer does not include

- execution of construction project and loads
- implementation of construction and electrical works
- a ground wire and cathode protection
- the implementation of operational UDT acceptance

Warranty

- warranty on module: 2 years
- warranty on tank: 10 years

Delivery time

6 weeks

