

LPG Sumps

LPG sump with cover

Ø1200 mm, h=700 mm

Sump type and code	Version
LPG1-ZZ 742-002-0010	LPG sump Ø1200 mm, h=700 mm with cover hot dip galvanized

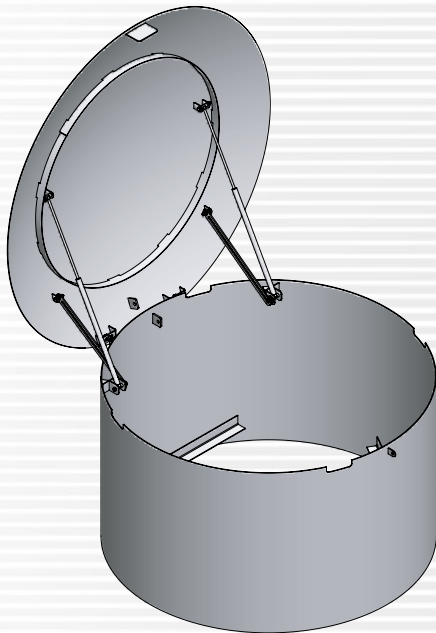

LPG sump, hot-dip galvanized
742-002-0010

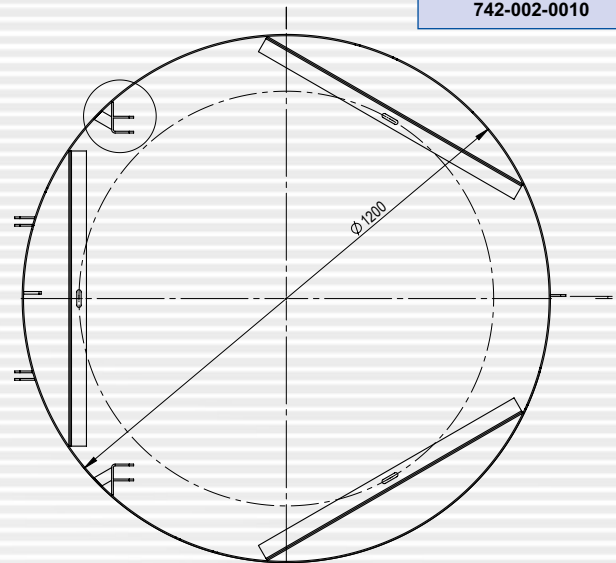

Method of mounting to the tank

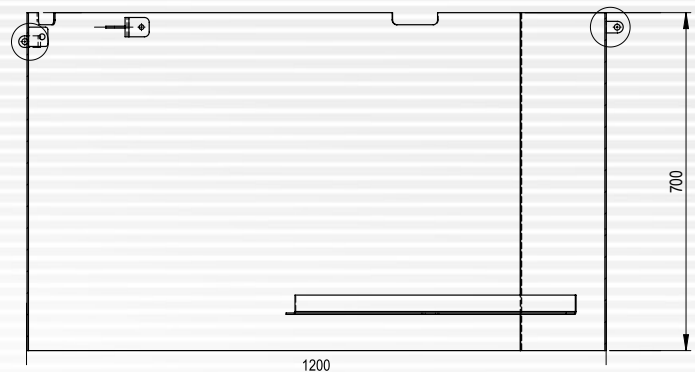
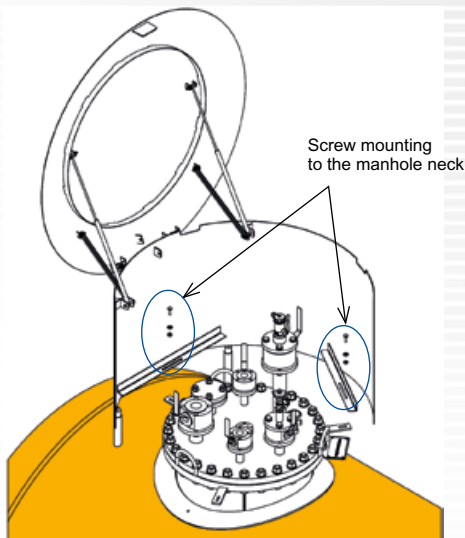

Modular LPG sump with two aluminum covers

1200x1770 mm, h=950 mm, S235 primer painted

Sump type and code	Version
LPG2-PA 741-000-0112	Modular LPG sump 1200x1770 mm h=950 mm, S235 painted with primer



← Modular LPG sump 741-000-0112

Method of mounting to the tank

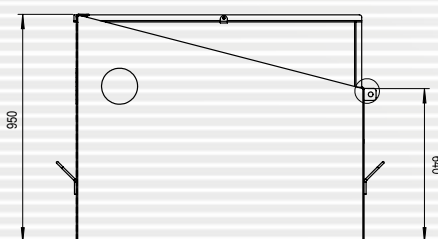
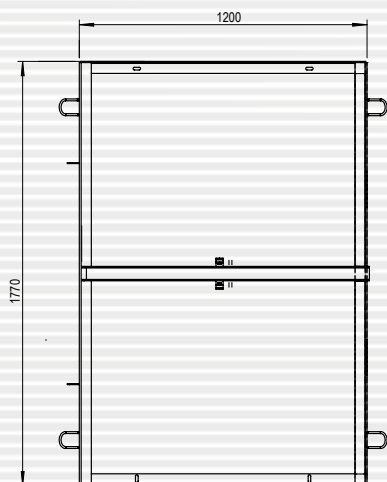
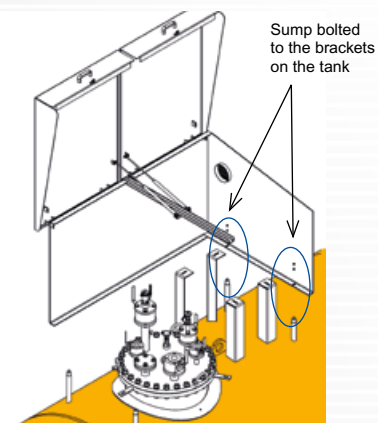

Modular LPG sump in INOX

1200x1770 mm, h=530 mm in INOX (304I / 1.4307)

Sump type and code	Version
LPG4 231-190-0002	Modular LPG INOX sump 1200x1770 mm, h=530 mm, steel 1.4307



← Modular LPG INOX sump 231-190-0002

Method of mounting to the tank

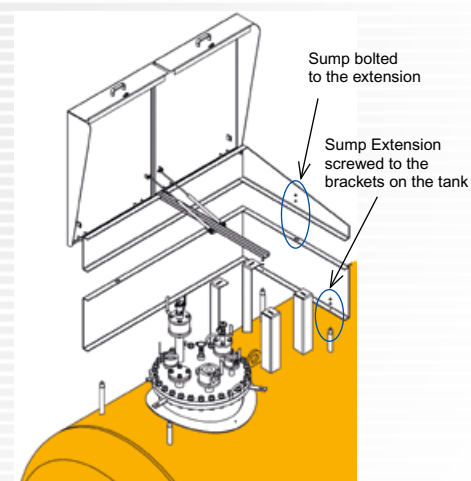

Base for modular sump

1200x1770 mm, h=470 mm, material S235, PUR coated

Sump type and code	Version
LPG3-E 743-000-0012	Base for modular sump, 1200x1770 mm, h=470 mm, painted with PUR



← Stand for a sump 743-000-0012

